

# Tocos Angle Sensor IC

Features and specifications of the angle sensor IC  
currently under development by TOCOS

# New Angle Sensor IC – General Description

Confidential

The **Tocos Angle Sensor IC** is a high-precision magnetic angle detection device integrating **AMR** (Anisotropic Magneto resistance) sensor bridges, mixed-signal processing circuits, and required capacitors into a single compact package.

The device outputs a **linear analog voltage proportional to the detected magnetic angle**.

## Dual AMR Sensor Bridges

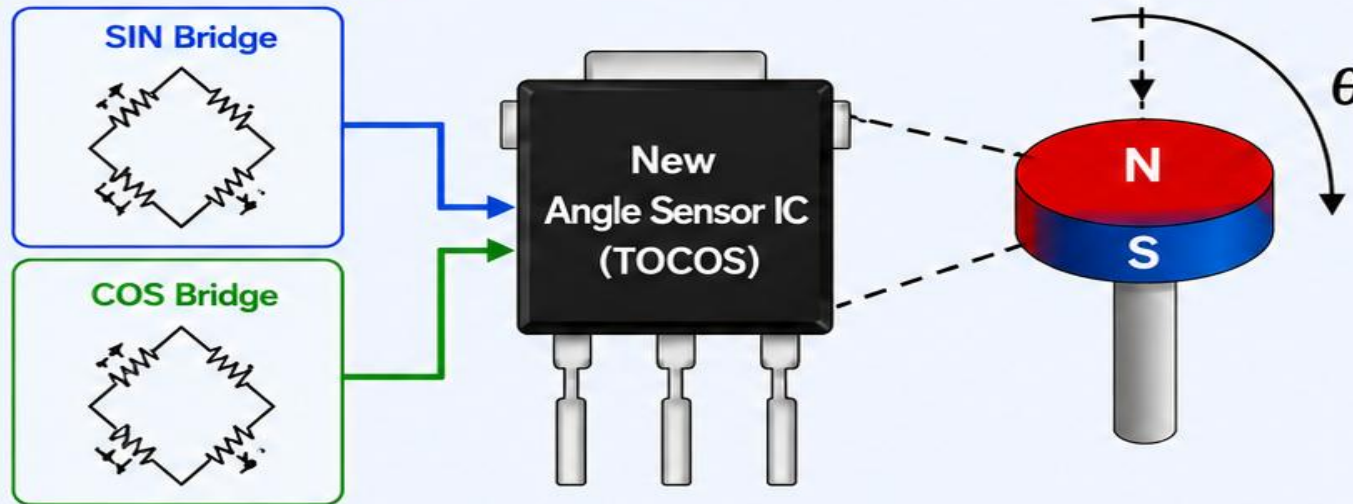

The IC calculates the angle  $\theta$  from the SIN and COS signals and outputs a **linear analog voltage**.

## Key Features



Supply voltage (VCC): **5.0V  $\pm$ 10%**  
Absolute Maximum Supply voltage: up to **18V**



Operating temperature: **-40°C to +140°C**



Detected angle: **0 ~ 180°**



Angular Accuracy / Resolution:  
 **$\pm 1.1^\circ / 0.04^\circ$  (12bit)**



- Reference angle, angle range setting
- Output upper/lower voltage limit settings



### Diagnostic Functions

- VCC Over voltage / Lower voltage
- ECC memory check
- Magnetic field loss, AMR disconnection, GND loss



### Single wire communication

- Writing to / reading from memory is possible via output pin at startup













Includes memory for informational storage

# TOCOS Angle Sensor IC

Magnetic Angle Sensor with Programmable Analog Output

## 1. CORE PRODUCT OVERVIEW

|                                                                                    |                         |                                                                                                                         |
|------------------------------------------------------------------------------------|-------------------------|-------------------------------------------------------------------------------------------------------------------------|
|    | Product                 | TOCOS (Tokai Rika) Sensor                                                                                               |
|    | Device Type             | Angle Sensor Integrated Circuit                                                                                         |
|    | Sensing Technology      | Dual AMR (Anisotropic Magneto-Resistive) Sensor Bridges                                                                 |
|    | Output Type             | Linear Analog Voltage Output                                                                                            |
|    | Angle Periodicity       | 180° Periodic                                                                                                           |
|    | Programmability         | Fully Programmable via Non-Volatile Memory (NVM) (Reference angle, Range, Clamp voltages, Slope direction & multiplier) |
|    | Communication Interface | One-Wire Interface (OWI) (For test mode / programming)                                                                  |
|    | Diagnostics             | Built-in comprehensive diagnostics and protection functions                                                             |
|    | Package                 | 3-Pin Compact Package                                                                                                   |
|  | Operating Temperature   | -40 °C to +140 °C                                                                                                       |
|  | Supply Voltage          | 4.5 V to 5.5 V                                                                                                          |

## TYPICAL APPLICATIONS



Steering Angle Sensor



Throttle / Pedal Sensor



Transmission Position Sensor



Valve / Actuator Sensor



Industrial Position Sensing



Off-Highway & Heavy Equipment

## PACKAGE & PIN CONFIGURATION

Top View

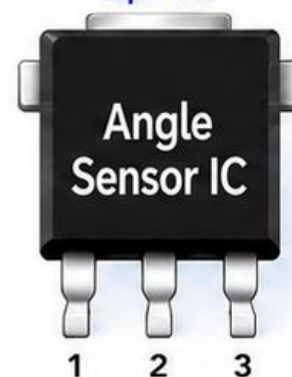

| Pin # | Pin Name | Function                                                                                                                                        |
|-------|----------|-------------------------------------------------------------------------------------------------------------------------------------------------|
| 1     | VCC      | Power supply (4.5 V to 5.5 V)                                                                                                                   |
| 2     | GND      | Ground                                                                                                                                          |
| 3     | OUT      | <ul style="list-style-type: none"> <li>Analog output (Voltage proportional to angle)</li> <li>One-Wire Communication (For test mode)</li> </ul> |

### OUT Pin Function:

During normal operation, OUT provides analog voltage proportional to the detected angle.

During test mode (OWI), the same pin is used for bidirectional one-wire communication.

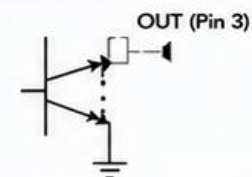

Analog Output  
or  
One-Wire Interface  
(For Test Mode)

## KEY CAPABILITIES



High Precision Angle Sensing

Detects magnetic angle with high accuracy



Programmable Output

Configurable angle range, reference, clamp voltages, slope and more



Robust Diagnostics

Integrated self-checks and fault detection with safe output override



Wide Environment

Operates reliably from -40 °C to +140 °C



Integrated Solution

Sensor + processing + memory + caps in a single IC

## Pin Configuration

The IC is a 3-pin rotation sensor IC with analog output and One-Wire communication interface.

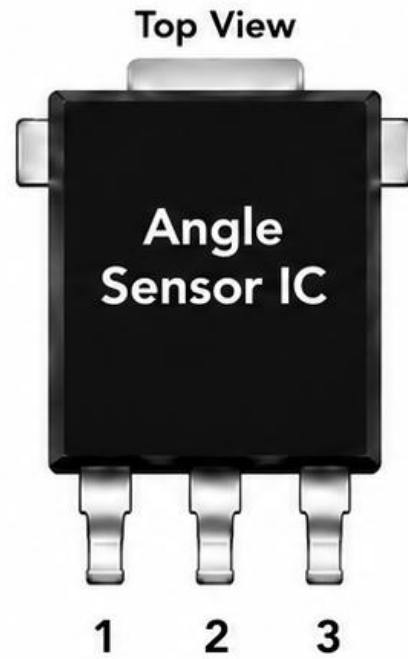

### Key Features

- Absolute max voltage rating 18V
- 180° periodic analog output
- One-Wire Interface (OWI) for test mode
- Built-in diagnostics and protection functions

### Pin Location (Bottom View)

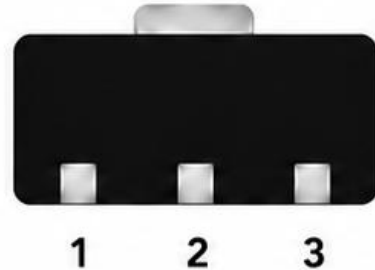

### Notes:

- All pins are designed to withstand automotive environment.
- For detailed electrical characteristics, please refer to the datasheet.

## Pin Description

| Pin # | Pin Name | Function                                                                                                                                         |
|-------|----------|--------------------------------------------------------------------------------------------------------------------------------------------------|
| 1     | VCC      | Power supply<br>Supply voltage: 4.5V to 5.5V                                                                                                     |
| 2     | GND      | Ground                                                                                                                                           |
| 3     | OUT      | <ul style="list-style-type: none"><li>• Analog output (Voltage proportional to angle)</li><li>• One-Wire Communication (For test mode)</li></ul> |

### About the OUT Pin

The OUT pin provides the analog output during normal operation. When entering test mode via the One-Wire Interface (OWI), the same pin is used for bidirectional communication.

### Internal Equivalent Circuit (Simplified)

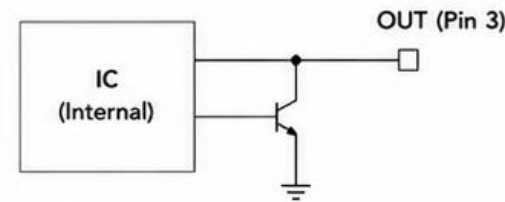

### Typical Connection

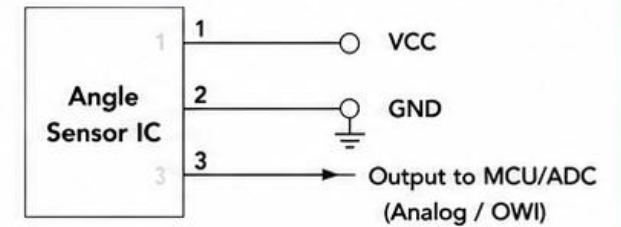

# Angle Sensor IC – Key Feature Summary

## 1. Main Functional Features



### Magnetic Angle Detection

- Uses dual MR/AMR sensor bridges
- Detects magnetic field direction parallel to sensor plane
- Provides precise non-contact rotational angle measurement



### Programmable Output Characteristics

The IC allows customization of:

- Reference / zero angle
- Measurement angle range
- Clamp voltages (high & low)
- Output slope direction
- Output slope multiplier

## 2. The IC Allows Customization Of:

| Parameter      | Description                        |
|----------------|------------------------------------|
| $\alpha$ ZERO  | Reference / zero angle             |
| $\alpha$ RANGE | Measurement angle range            |
| VHI            | High clamp voltage                 |
| VLO            | Low clamp voltage                  |
| SLOPE_DIR      | Rising or falling output direction |
| SLOPE_MULTI    | Output slope multiplier            |

## 3. Analog Output Characteristics

| Parameter          | Specification                |
|--------------------|------------------------------|
| Output Type        | Linear analog voltage        |
| Output Periodicity | 180°                         |
| Angle Resolution   | 0.04°                        |
| Angle Accuracy     | ±1.1°                        |
| Update Rate        | 250–300 $\mu$ s              |
| Output Direction   | Rising or Falling selectable |
| Diagnostic Output  | <4% VCC or >96% VCC          |

## 4. Programmable Angle & Voltage Ranges



### Angle Configuration

| Parameter                       | Min | Max  |
|---------------------------------|-----|------|
| Standard Angle ( $\alpha$ ZERO) | 0°  | 180° |
| Angle Range ( $\alpha$ RANGE)   | 10° | 180° |



### Clamp Voltage Configuration

| Parameter        | Min     | Max     |
|------------------|---------|---------|
| Clamp Low (VLO)  | 7% VCC  | 45% VCC |
| Clamp High (VHI) | 55% VCC | 93% VCC |

## 5. Electrical Specifications

### Supply & Power

| Parameter                 | Min  | Typ  | Max  |
|---------------------------|------|------|------|
| Supply Voltage            | 4.5V | 5.0V | 5.5V |
| Maximum Supply Capability | —    | —    | 18V  |
| Current Consumption       | —    | 7mA  | 10mA |

### Start-Up Characteristics

| Parameter           | Value    |
|---------------------|----------|
| Start Time          | ≤5 ms    |
| POR Release Voltage | 3.2V typ |
| POR Detect Voltage  | 3.1V typ |



# Angle Sensor IC – Specifications Summary

## 6. Environmental & Reliability Specifications



| Parameter             | Specification    |
|-----------------------|------------------|
| Operating Temperature | -40°C to +140°C  |
| Junction Temperature  | Up to 150°C      |
| Storage Temperature   | -50°C to +150°C  |
| NVM Retention         | 10 years         |
| NVM Endurance         | 100 write cycles |
| Thermal Resistance    | 135 °C/W         |

## 7. Magnetic Requirements









| Parameter                                                                                                | Specification                  |
|----------------------------------------------------------------------------------------------------------|--------------------------------|
|  Magnetic Flux Density | ≥30 mT                         |
|  Sensing Type          | External magnetic field vector |
|  Sensing Orientation   | Parallel to MR sensor plane    |

## 8. Diagnostic & Functional Safety Features



The IC includes extensive built-in diagnostics for automotive and industrial reliability.







### Integrated Diagnostic Functions

| Diagnostic Function                                                                                               | Purpose                          |
|-------------------------------------------------------------------------------------------------------------------|----------------------------------|
|  ECC NVM Check                 | Memory integrity                 |
|  Register Integrity Check      | Detects corrupted register data  |
|  MR Wire Open Detection        | Detects sensor wiring faults     |
|  Magnetic Field Loss Detection | Detects missing magnet           |
|  Over-Voltage Detection        | Protects against VCC overvoltage |
|  Under-Voltage Detection       | Detects low supply voltage       |
|  Ground Open Detection         | Detects GND failure              |
|  Power-On Reset                | Startup reliability              |
|  Diagnostic Output Override    | Fault signaling                  |

## 9. ECC & Memory Architecture



### NVM Features

| Feature                                                                                                         | Specification              |
|-----------------------------------------------------------------------------------------------------------------|----------------------------|
|  Memory Type                  | Non-Volatile Memory        |
|  ECC Protection              | Yes                        |
|  Single Bit Error Correction | Supported                  |
|  Double Bit Error Detection  | Supported                  |
|  Unique ID                   | 44-bit identification code |
|  Memory Lock                 | Permanent write protection |

## 10. One-Wire Interface (OWI)



The IC supports bidirectional communication over the OUT pin for:



Programming



Calibration



Testing



Memory access

### OWI Characteristics

| Parameter          |                      | Specification                                                                                           |               |
|--------------------|----------------------|---------------------------------------------------------------------------------------------------------|---------------|
| Communication Type | Synchronous one-wire |  Bit Time          | 210 μs        |
| Logic Levels       | VCC / ½VCC / GND     |  Test Mode Timeout | 10 s          |
| Command Length     | 25 bits              |  Memory Write Time | 2 ms per byte |

# New TOCOS angle sensor IC vs. leading Hall-based angle sensor ICs

Confidential

| Specification                    | New Angle Sensor IC | MLX90365          | AS5171A                | Remark                          |
|----------------------------------|---------------------|-------------------|------------------------|---------------------------------|
| IC supplier                      | TOCOS (Tokai Rika)  | Melexis           | Infineon (Osram)       |                                 |
| Angle sensor                     | AMR                 | Hall              | Hall                   |                                 |
| Interface                        | Analog              | Analog + PWM      | Analog + SENT          |                                 |
| Internal Chip Configuration      | 2chip (AMR+ASIC)    | 1chip (Hall+ASIC) | 1chip (Hall+ASIC)      |                                 |
| Package                          | SIP                 | DMP-4             | SIP Built-in Capacitor |                                 |
| Thermal resistance               | 135K/W              | 88.7K/W           | 114.55K/W              |                                 |
| Package (dual die)               | ---                 | SMP-4             | --- Built-in Capacitor |                                 |
| Thermal resistance (dual die)    | ---                 | 140K/W            | ---                    |                                 |
| External magnetic field strength | >30mT               | 70-20mT           | 90-10mT                |                                 |
| Maximum Angle                    | 0-180deg            | 0-359.9deg        | 0-360deg               | Hall:360deg, AMR:180deg         |
| Angular accuracy                 | ±1.1deg             | ±1.8deg           | ±1.4deg                |                                 |
| Angular resolution               | 12bit (0.044deg)    | 12bit (0.08deg)   | 12bit (0.08deg)        |                                 |
| ISO26262                         | ASIL B              | ASIL B            | ASIL B                 |                                 |
| AEC-Q100                         | Grade0              | Grade0            | Grade0                 |                                 |
| Operating temperature range      | -40°C ~ 140°C       | -40°C ~ 160°C     | -40°C ~ 150°C          |                                 |
| Maximum Voltage                  | 18V                 | 24V               | 20V                    | Absolute max voltage rating 18V |
| Operational Voltage              | 4.5V-5.5V           | 4.5V-5.5V         | 4.5V-5.5V              |                                 |
| Current Consumption (max/typ)    | 10mA / 7mA          | 12mA / 8mA        | 12mA / ---             |                                 |
| Internal memory (NVM)            | 44Bit               | 128B              | 16bit                  |                                 |
| Wake-up Time                     | 5ms                 | 5ms               | 10ms                   |                                 |
| Data update interval             | 300us               | 448us             | 125us                  |                                 |



High Accuracy  
±1.1° (best in class)



High Resolution  
0.04° (12-bit)



Low Power  
7 mA typ.



Strong Field Capability  
>30 mT



Wide Temperature  
-40°C ~ 140°C



Automotive Grade  
AEC-Q100 Grade 0

## Comparison between TOCOS sensors and other sensors



**Higher angular accuracy, resolution**



**Lower power consumption**



**Higher magnetic field requirement:**  
no limitation under strong magnetic fields  
(Hall sensors have limitations under strong fields)



**Operating temperature range is not the widest,  
but sufficient for practical applications**



**Compared to Hall sensors, AMR sensors offer:**

- ✓ Higher accuracy
- ✓ Stronger immunity to external magnetic fields
- ✓ Better noise resistance
- ✓ Lower temperature drift



**Angular sensing range is 0–180°, narrower than Hall sensors (0–360°), but can provide performance advantages depending on the application**



**All products are AEC-Q100 Grade 0 compliant, suitable for automotive applications**

# Tocos Angle Sensor IC

Magnetic Angle Sensor with Programmable Analog Output

## Likely Target Applications

Based on the specifications, the IC is highly suitable for:



### Automotive



Throttle position sensing



Steering angle sensing



Transmission position sensing



Pedal position sensing



Valve position sensing



### Heavy Equipment / Off-Highway



Hydraulic joystick sensing



Boom/bucket angle sensing



Transmission controls



Actuator feedback



### Industrial



Rotary encoders



Motor position sensing



Servo feedback



Valve control systems



The Tocos Angle Sensor IC provides precise angle measurement with a linear analog output and customizable parameters, making it ideal for a wide range of automotive, off-highway, and industrial position sensing applications.

# Tocos Angle Sensor IC

## Functional Block Diagram

This is a magnetic angle sensor IC that integrates dual MR sensor bridges, signal processing, diagnostics, NVM and interface in a single chip.

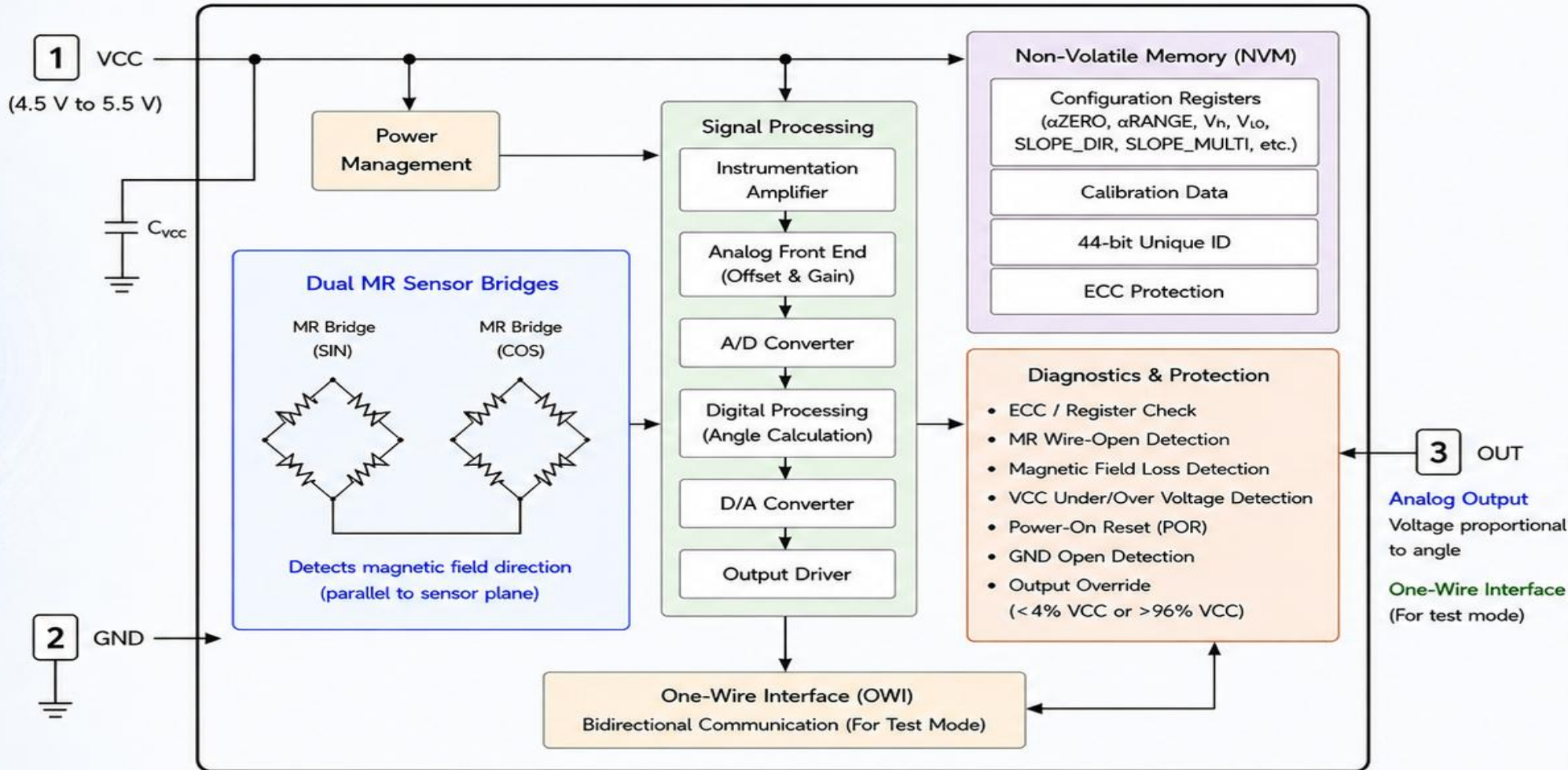

### 1. Dual MR Sensor Bridges

Two orthogonal MR bridges (SIN & COS) detect the external magnetic field components.

### 2. Signal Processing

Amplifies, digitizes and processes the sensor signals to calculate angle. The result is converted to an analog voltage proportional to angle.

### 3. Non-Volatile Memory (NVM)

Stores all configurable parameters, calibration data and unique ID. ECC ensures memory integrity.

### 4. Diagnostics & Protection

Continuously monitors device and environment to detect faults and forces the output to a safe level when a fault occurs.

### 5. One-Wire Interface (OWI)

Used to read/write registers, program parameters, read ID and perform diagnostics during test mode.

#### Note:

During normal operation, the OUT pin outputs analog voltage proportional to the detected angle. When entering test mode, the same pin is used for One-Wire bidirectional communication.

→ Signal Flow  
— Power / Reference

# Principle of Angle Detection Using an AMR Sensor (AMRセンサ 角度検出原理)

Confidential

The AMR angle sensor utilizes the magnetoresistive effect, in which the resistance of a magnetic material changes depending on the relationship between its magnetization direction and the surrounding magnetic field. The magnetic field generated by a magnet placed parallel to the AMR sensor IC is detected using two Wheatstone bridge-configured AMR sensor pairs, arranged with a 45-degree phase offset. Variations in resistance produce two output voltages corresponding to sin and cos waveforms, enabling detection of the magnet rotation angle  $\alpha$ . Since an AMR sensor cannot distinguish between the N and S poles of a magnet, the detectable angle range is 180 degrees.

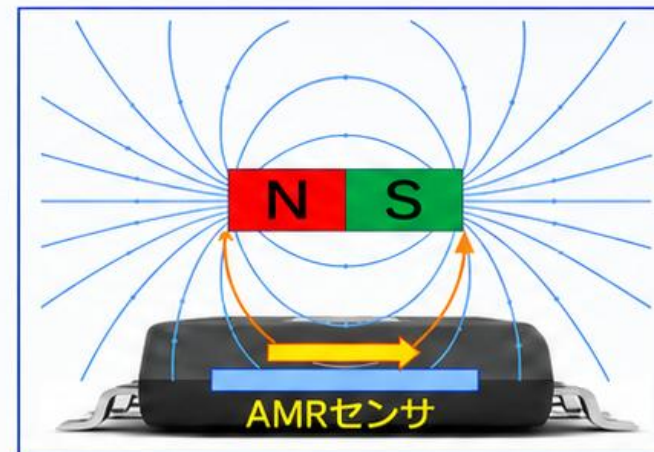

In-plane magnetic field component

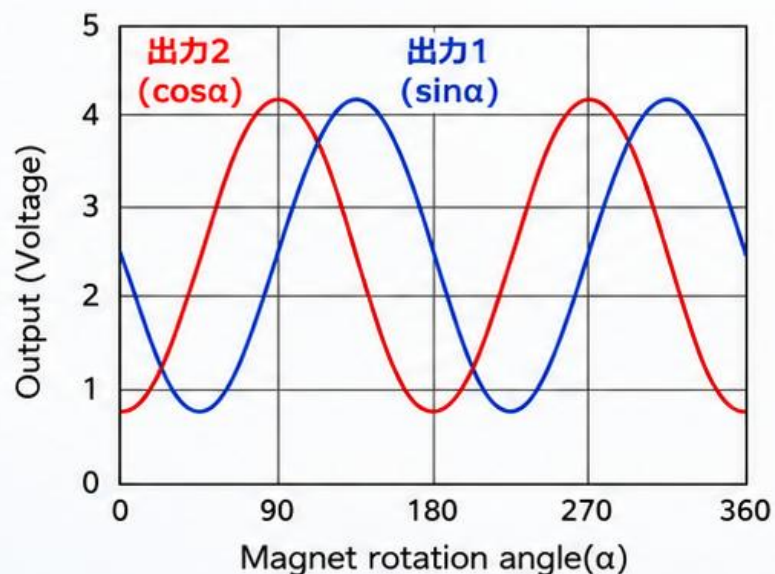
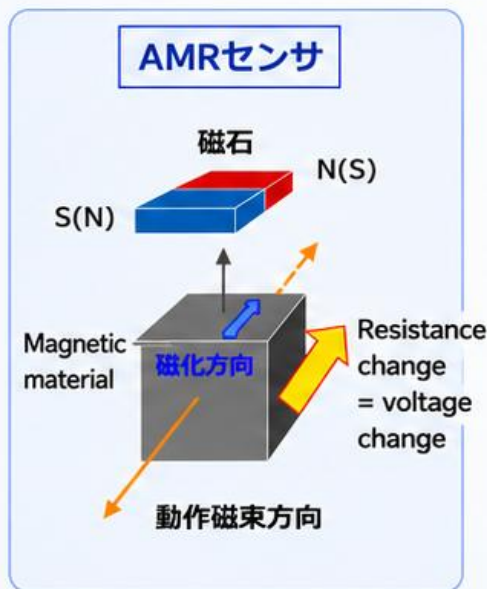

Two sets of AMR sensors configured in Wheatstone bridge structures (arranged with a 45-degree offset)

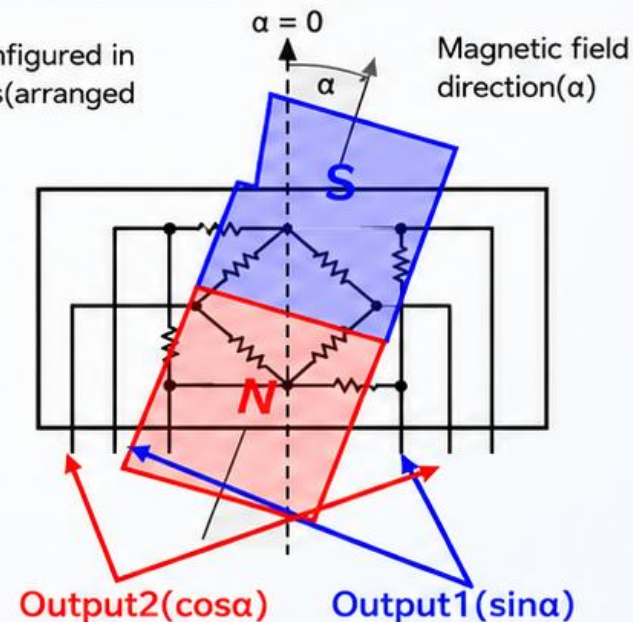

# Principle of Angle Detection Using a Hall Sensor (Hallセンサ 角度検出原理)

Confidential

The Hall angle sensor uses the Hall effect, in which a voltage is generated in a direction perpendicular to both the current flow and the magnetic field. A magnetic field perpendicular to the angle sensor IC is generated by a facing magnet. The voltages output from four Hall sensors integrated on the IC are combined to generate two output signals corresponding to  $\sin\theta$  and  $\cos\theta$ , allowing detection of the magnet rotation angle  $\theta$ .

$$\text{Signal1} = +V_{HS1} + V_{HS2} - V_{HS3} - V_{HS4} \leftarrow \sin\theta$$

$$\text{Signal2} = +V_{HS1} - V_{HS2} - V_{HS3} + V_{HS4} \leftarrow \cos\theta$$

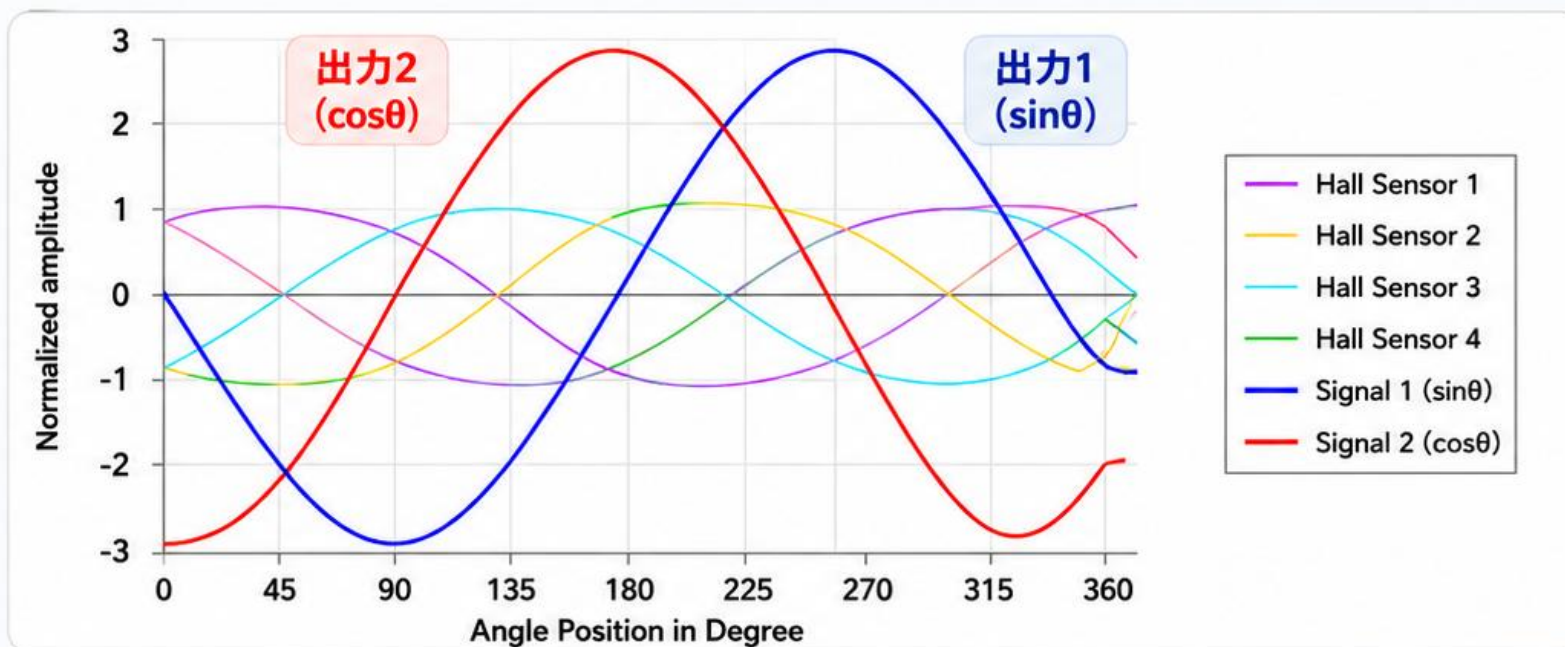
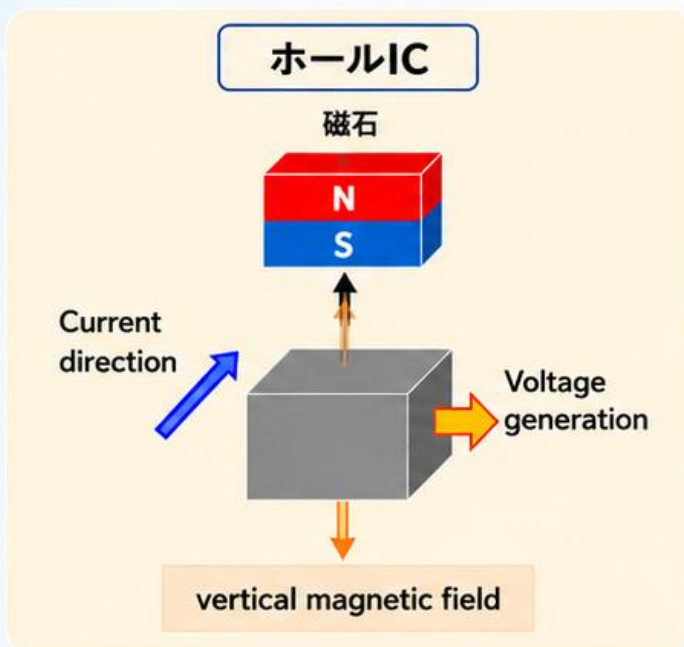

# Comparison of Angle Detection Principles: Hall Sensor vs. AMR Sensor (HallセンサとAMRセンサの角度検出原理比較)

Confidential

## Hall sensor

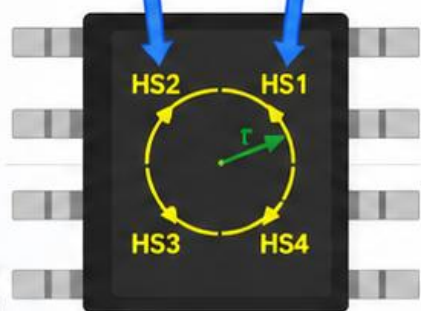
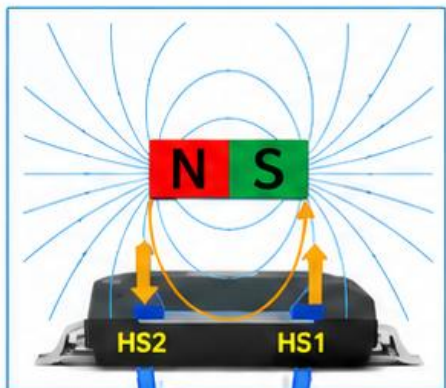

Four Hall sensors arranged concentrically (HS1/2/3/4)

4つのセンサから角度を計算

$$\text{Signal1} = +V_{HS1} + V_{HS2} - V_{HS3} - V_{HS4} \propto \sin\theta$$

$$\text{Signal2} = +V_{HS1} - V_{HS2} - V_{HS4} + V_{HS4} \propto \cos\theta$$

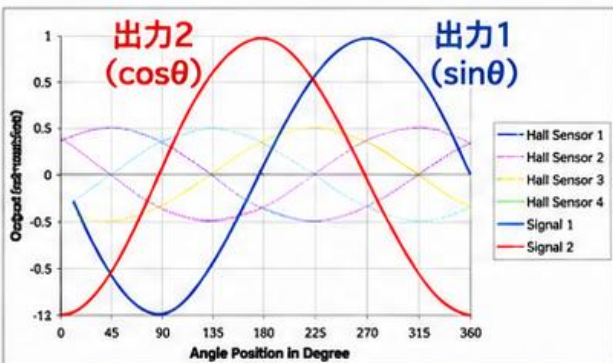

IC supplier:  
Melexis,  
Infineon(OSRAM)

The AMR sensor measures the output of bridge structures composed of four combined sensor elements.  
The Hall sensor calculates the angle by processing the outputs of four independent sensors.



## AMR sensor

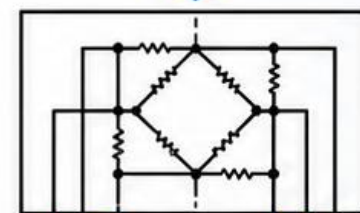
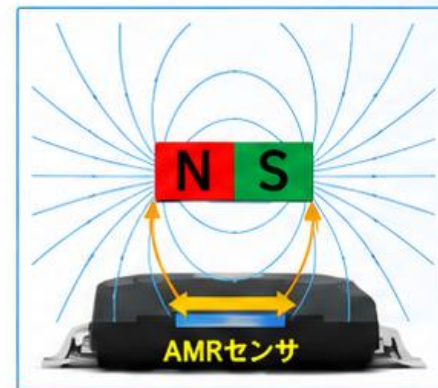

Measure outputs from two sets of AMR sensors  
※Wheatstone bridge structures arranged with a 45-degree offset

出力2(cosθ)      出力1(sinθ)

IC supplier:  
TOCOS (Tokai Rika)

# Definition of Sensor Accuracy (INL, temp. drift, etc.) (analog output)

Confidential

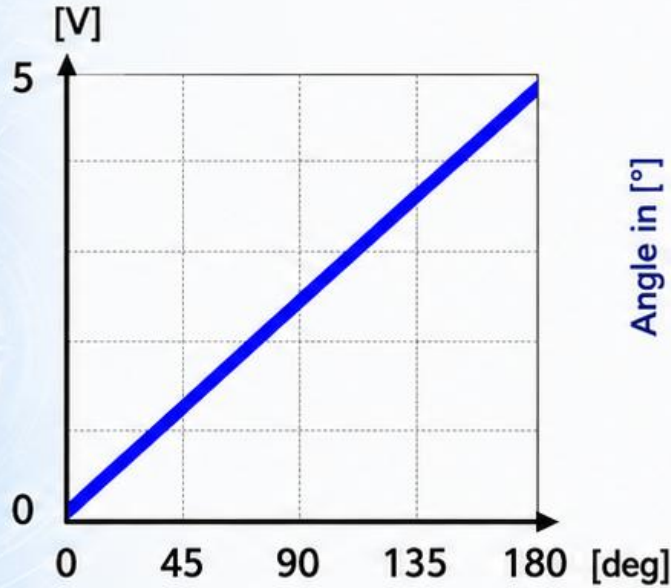

Angle input – Analog output

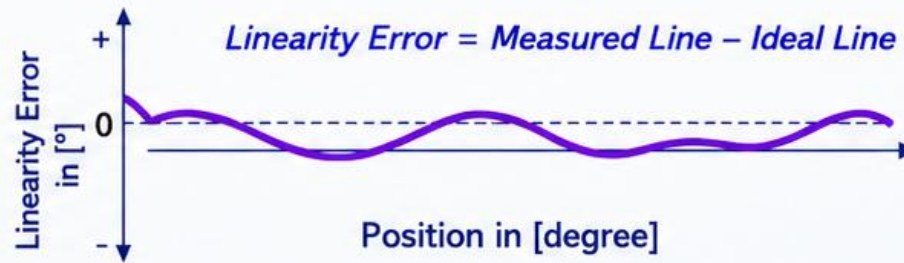
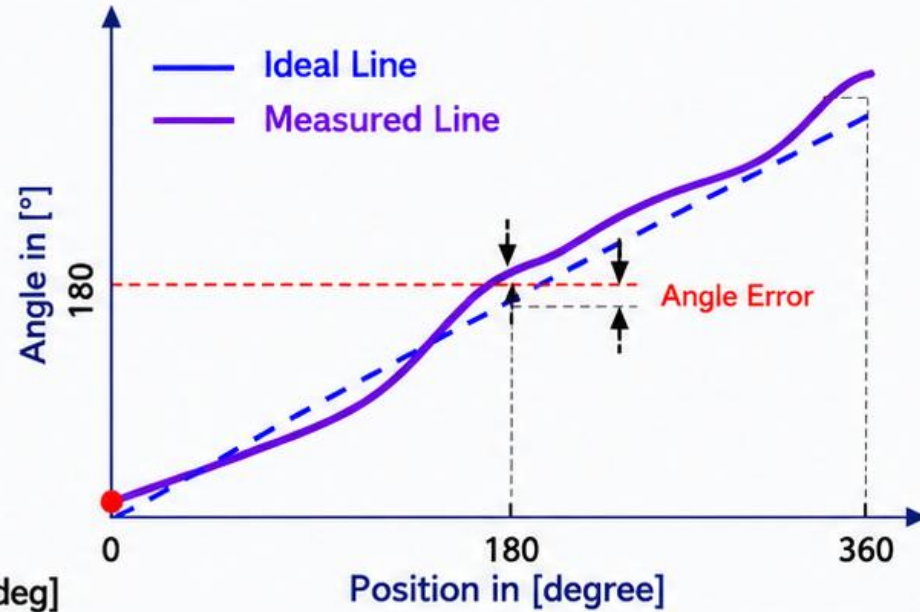

Non-linearity of the angle output

$$\text{INL Error} = \frac{\text{Linearity Error max} - \text{Linearity Error min}}{2}$$

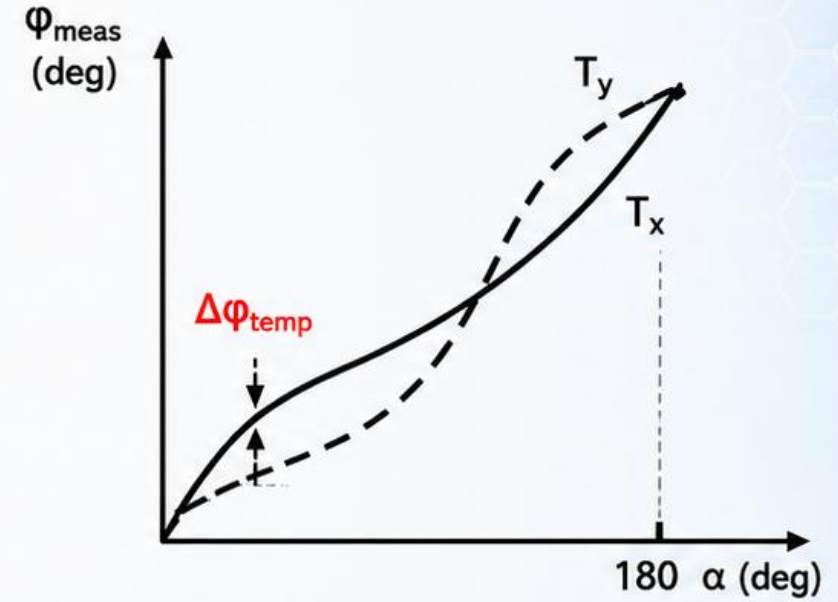

001aag816

Definition of the temperature drift error

- $T_x$  : Output at low temperature
- $T_y$  : Output at high temperature
- $\Delta\phi_{\text{temp}}$  : Difference in angle due to temperature change

# Angle Sensor IC Development Schedule (FY26: Start of Sales)

Confidential

## Start of sales activities

Marketing / Sales

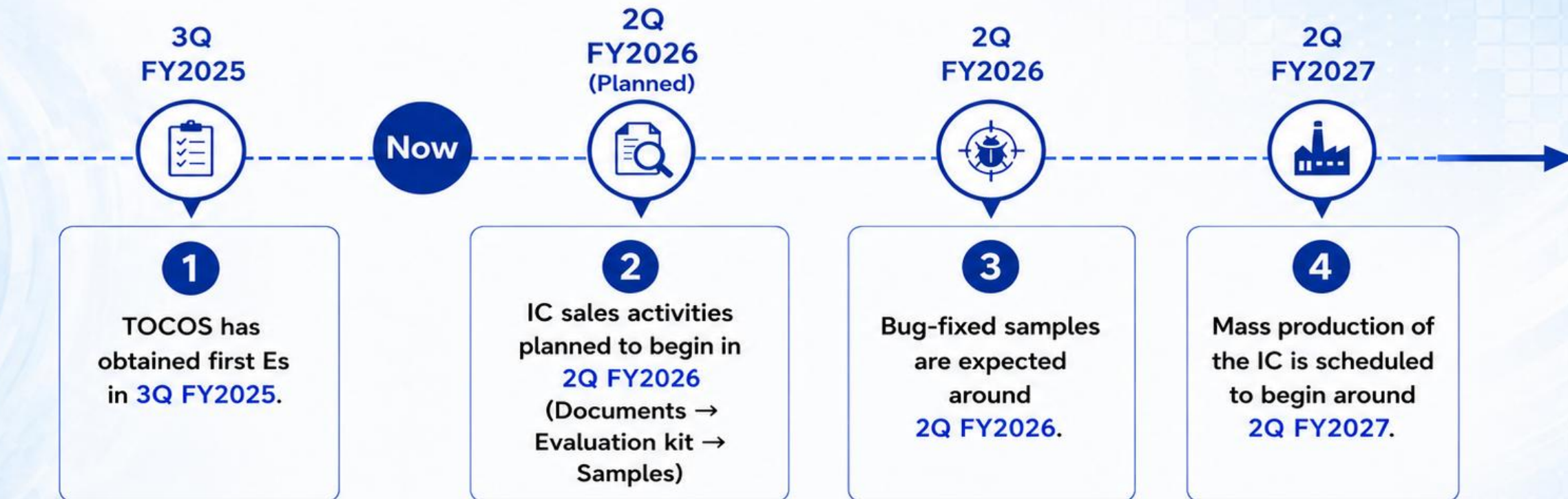

TOCOS will begin IC sales activities in 2Q FY2026, starting with documents, followed by evaluation kits and samples. Bug-fixed samples are expected in 2Q FY2026, and mass production is scheduled to begin in 2Q FY2027.