

# **TOCOS** Angle Sensor IC

Features and specifications of the angle sensor IC  
currently under development by TOCOS

# New Angle Sensor IC – General Description

The **TOCOS** Angle Sensor IC is a high-precision magnetic angle detection device integrating **AMR** (Anisotropic Magneto resistance) sensor bridges, mixed-signal processing circuits, and required capacitors into a single compact package.

The device outputs a **linear analog voltage proportional to the detected magnetic angle**.

## Dual AMR Sensor Bridges

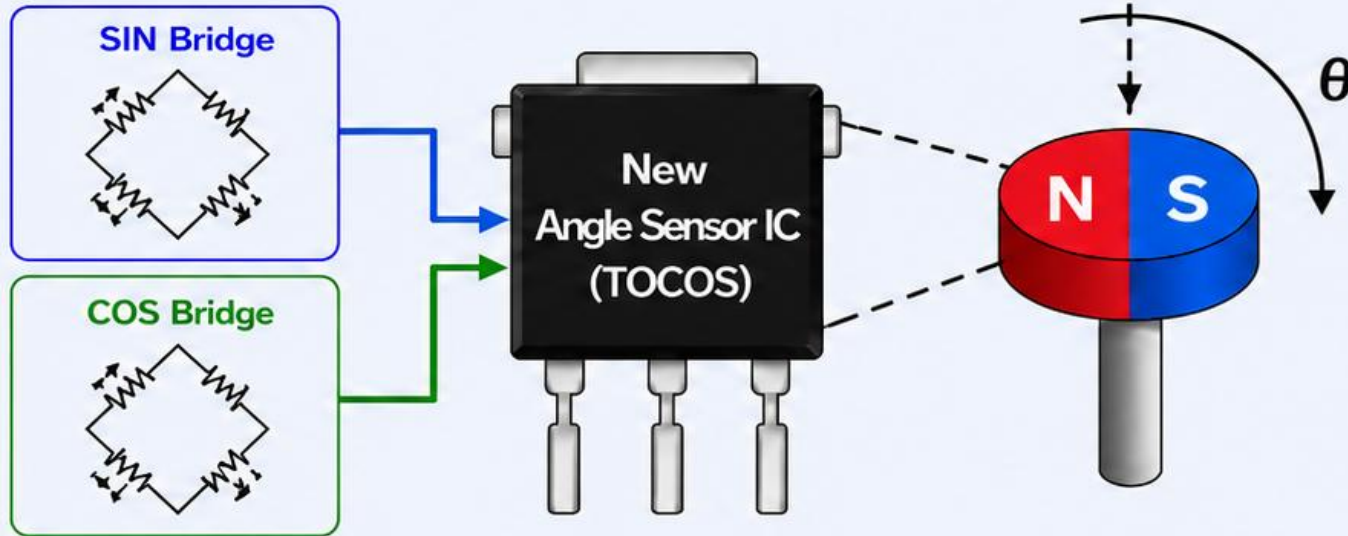

The IC calculates the angle  $\theta$  from the SIN and COS signals and outputs a **linear analog voltage**.

## Key Features



Supply voltage (VCC): **5.0V  $\pm$ 10%**  
Absolute Maximum Supply voltage: up to **18V**



Operating temperature: **-40°C to +140°C**



Detected angle: **0 ~ 180°**



Angular Accuracy / Resolution:  
 **$\pm 1.1^\circ$  /  $0.04^\circ$  (12bit)**



- Reference angle, angle range setting
- Output upper/lower voltage limit settings



### Diagnostic Functions

- VCC Over voltage / Lower voltage
- ECC memory check
- Magnetic field loss, AMR disconnection, GND loss



### Single wire communication

- Writing to / reading from memory is possible via output pin at startup













Includes memory for informational storage

# TOCOS Angle Sensor IC

Magnetic Angle Sensor with Programmable Analog Output

## 1. CORE PRODUCT OVERVIEW

	Product	TOCOS (Tokai Rika) Sensor
	Device Type	Angle Sensor Integrated Circuit
	Sensing Technology	Dual AMR (Anisotropic Magneto-Resistive) Sensor Bridges
	Output Type	Linear Analog Voltage Output
	Angle Periodicity	180° Periodic
	Programmability	Fully Programmable via Non-Volatile Memory (NVM) (Reference angle, Range, Clamp voltages, Slope direction & multiplier)
	Communication Interface	One-Wire Interface (OWI) (For test mode / programming)
	Diagnostics	Built-in comprehensive diagnostics and protection functions
	Package	3-Pin Compact Package
	Operating Temperature	-40 °C to +140 °C
	Supply Voltage	4.5 V to 5.5 V

## TYPICAL APPLICATIONS



Steering Angle Sensor



Throttle / Pedal Sensor



Transmission Position Sensor



Valve / Actuator Sensor



Industrial Position Sensing



Off-Highway & Heavy Equipment

## PACKAGE & PIN CONFIGURATION

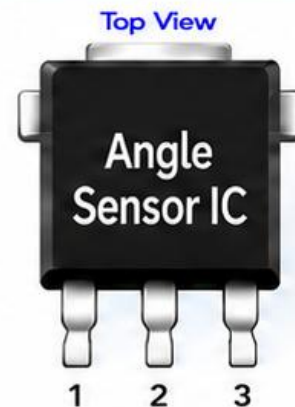

Pin #	Pin Name	Function
1	VCC	Power supply (4.5 V to 5.5 V)
2	GND	Ground
3	OUT	<ul style="list-style-type: none"><li>Analog output (Voltage proportional to angle)</li><li>One-Wire Communication (For test mode)</li></ul>

### OUT Pin Function:

During normal operation, OUT provides analog voltage proportional to the detected angle.

During test mode (OWI), the same pin is used for bidirectional one-wire communication.

Analog Output  
or  
One-Wire Interface  
(For Test Mode)

## KEY CAPABILITIES



High Precision Angle Sensing

Detects magnetic angle with high accuracy



Programmable Output

Configurable angle range, reference, clamp voltages, slope and more



Robust Diagnostics

Integrated self-checks and fault detection with safe output override



Wide Environment

Operates reliably from -40 °C to +140 °C



Integrated Solution

Sensor + processing + memory + caps in a single IC

## Pin Configuration

The IC is a 3-pin rotation sensor IC with analog output and One-Wire communication interface.

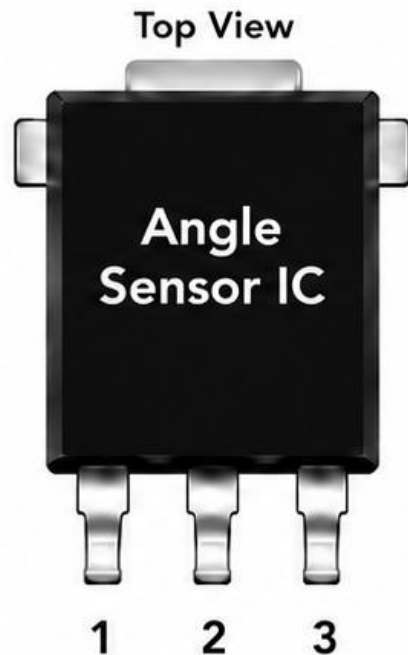

### Key Features

- Absolute max voltage rating 18V
- 180° periodic analog output
- One-Wire Interface (OWI) for test mode
- Built-in diagnostics and protection functions

Pin Location (Bottom View)

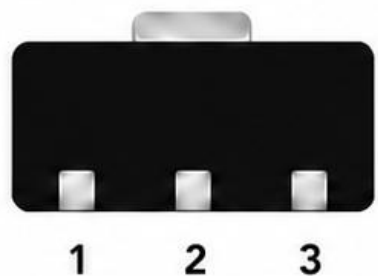

### Notes:

- All pins are designed to withstand automotive environment.
- For detailed electrical characteristics, please refer to the datasheet.

## Pin Description

Pin #	Pin Name	Function
1	VCC	Power supply Supply voltage: 4.5V to 5.5V
2	GND	Ground
3	OUT	<ul style="list-style-type: none"><li>• Analog output (Voltage proportional to angle)</li><li>• One-Wire Communication (For test mode)</li></ul>

### About the OUT Pin

The OUT pin provides the analog output during normal operation.

When entering test mode via the One-Wire Interface (OWI), the same pin is used for bidirectional communication.

When supply voltage is applied, OWI is enabled during designated term.

Typical Connection

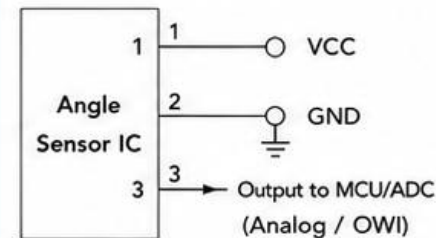

# Angle Sensor IC – Key Feature Summary

## 1. Main Functional Features



### Magnetic Angle Detection

- Uses dual AMR sensor bridges
- Detects magnetic field direction parallel to sensor plane
- Provides precise non-contact rotational angle measurement



### Programmable Output Characteristics

The IC allows customization of:

- Reference / zero angle
- Measurement angle range
- Clamp voltages (high & low)
- Output slope direction
- Output slope multiplier

## 2. The IC Allows Customization Of:

Parameter	Description
$\alpha$ ZERO	Reference / zero angle
$\alpha$ RANGE	Measurement angle range
VHI	High clamp voltage
VLO	Low clamp voltage
SLOPE_DIR	Rising or falling output direction
SLOPE_MULTI	Output slope multiplier

## 3. Analog Output Characteristics

Parameter	Specification
Output Type	Linear analog voltage
Output Periodicity	180°
Angle Resolution	0.04°
Angle Accuracy	±1.1°
Update Rate	250–300 $\mu$ s
Output Direction	Rising or Falling selectable
Diagnostic Output	<4% VCC or >96% VCC

## 4. Programmable Angle & Voltage Ranges



### Angle Configuration

Parameter	Min	Max
Standard Angle ( $\alpha$ ZERO)	0°	180°
Angle Range ( $\alpha$ RANGE)	10°	180°



### Clamp Voltage Configuration

Parameter	Min	Max
Clamp Low (VLO)	7% VCC	45% VCC
Clamp High (VHI)	55% VCC	93% VCC

## 5. Electrical Specifications

### Supply & Power

Parameter	Min	Typ	Max
Supply Voltage	4.5V	5.0V	5.5V
Absolute Maximum Voltage	—	—	18V
Current Consumption	—	7mA	10mA

### Start-Up Characteristics

Parameter	Value
Start Time	≤5 ms
POR Release Voltage	3.2V typ
POR Detect Voltage	3.1V typ



# Angle Sensor IC – Specifications Summary

## 6. Environmental & Reliability Specifications



Parameter	Specification
Operating Temperature	-40°C to +140°C
Junction Temperature	Up to 150°C
Storage Temperature	-50°C to +150°C
NVM Retention	10 years
NVM Endurance	100 write cycles
Thermal Resistance	135 °C/W

## 7. Magnetic Requirements









Parameter	Specification
 Magnetic Flux Density	≥30 mT
 Sensing Type	External magnetic field vector
 Sensing Orientation	Parallel to MR sensor plane

## 8. Diagnostic & Functional Safety Features



The IC includes extensive built-in diagnostics for automotive and industrial reliability.







### Integrated Diagnostic Functions

Diagnostic Function	Purpose
 ECC NVM Check	Memory integrity
 Register Integrity Check	Detects corrupted register data
 MR Wire Open Detection	Detects sensor wiring faults
 Magnetic Field Loss Detection	Detects missing magnet
 Over-Voltage Detection	Protects against VCC overvoltage
 Under-Voltage Detection	Detects low supply voltage
 Ground Open Detection	Detects GND failure
 Power-On Reset	Startup reliability
 Diagnostic Output Override	Fault signaling

## 9. ECC & Memory Architecture



### NVM Features

Feature	Specification
 Memory Type	Non-Volatile Memory
 ECC Protection	Yes
 Single Bit Error Correction	Supported
 Double Bit Error Detection	Supported
 Unique ID	44-bit identification code
 Memory Lock	Permanent write protection

## 10. One-Wire Interface (OWI)



The IC supports bidirectional communication over the OUT pin for:



Programming



Calibration





Testing



Memory access

### OWI Characteristics

Parameter	Specification
Communication Type	Synchronous one-wire
Logic Levels	VCC / ½VCC / GND
Command Length	25 bits

Specification	Specification
 Bit Time	210 μs
 Test Mode Timeout	10 s
 Memory Write Time	2 ms per byte

# New TOCOS angle sensor IC vs. leading Hall-based angle sensor ICs

Specification	New Angle Sensor IC	MLX90365	AS5171A	Remark
IC supplier	TOCOS (Tokai Rika)	Melexis	Infineon (Osram)	
Angle sensor	AMR	Hall	Hall	
Interface	Analog	Analog + PWM	Analog + SENT	
Internal Chip Configuration	2chip (AMR+ASIC)	1chip (Hall+ASIC)	1chip (Hall+ASIC)	
Package	SIP	DMP-4	SIP Built-in Capacitor	
Thermal resistance	135K/W	88.7K/W	114.55K/W	
Package (dual die)	---	SMP-4	--- Built-in Capacitor	
Thermal resistance (dual die)	---	140K/W	---	
External magnetic field strength	>30mT	70-20mT	90-10mT	
Maximum Angle	0-180deg	0-359.9deg	0-360deg	Hall: 360deg, AMR: 180deg
Angular accuracy	±1.1deg	±1.8deg	±1.4deg	
Angular resolution	12bit (0.044deg)	12bit (0.08deg)	12bit (0.08deg)	
ISO26262	ASIL B	ASIL B	ASIL B	
AEC-Q100	Grade0	Grade0	Grade0	
Operating temperature range	-40°C ~ 140°C	-40°C ~ 160°C	-40°C ~ 150°C	
Maximum Voltage	18V	24V	20V	Absolute max voltage rating 18V
Operational Voltage	4.5V-5.5V	4.5V-5.5V	4.5V-5.5V	
Current Consumption (max/typ)	10mA / 7mA	12mA / 8mA	12mA / ---	
Internal memory (NVM)	44Bit	128 Byte	16 Bit	
Wake-up Time	5ms	5ms	10ms	
Data update interval	300us	448us	125us	



**High Accuracy**  
±1.1° (best in class)



**High Resolution**  
0.04° (12-bit)



**Low Power**  
7 mA typ.



**Strong Field Capability**  
>30 mT



**Wide Temperature**  
-40°C ~ 140°C



**Automotive Grade**  
AEC-Q100 Grade 0

# TOCOS Sensor – Strengths

## Comparison between TOCOS sensors and other sensors



**Higher angular accuracy, resolution**



**Lower power consumption**



**Higher magnetic field capability:**  
no limitation under strong magnetic fields  
(Hall sensors have limitations under strong fields)



**Operating temperature range is not the widest,  
but sufficient for practical applications**



**Compared to Hall sensors, AMR sensors offer:**

- ✓ Higher accuracy
- ✓ Stronger immunity to external magnetic fields
- ✓ Better noise resistance
- ✓ Lower temperature drift



**Angular sensing range is 0–180°, narrower than Hall sensors (0–360°), but can provide performance advantages depending on the application**



**All products are AEC-Q100 Grade 0 compliant, suitable for automotive applications**

# TOCOS ANGLE SENSOR IC

Magnetic Angle Sensor with Programmable Analog Output

## Likely Target Applications

Based on the specifications, the IC is highly suitable for:



### AUTOMOTIVE



THROTTLE POSITION SENSING



STEERING ANGLE SENSING



TRANSMISSION POSITION SENSING



PEDAL POSITION SENSING



VALVE POSITION SENSING



### HEAVY EQUIPMENT / OFF-HIGHWAY



HYDRAULIC JOYSTICK SENSING



BOOM/BUCKET ANGLE SENSING



TRANSMISSION CONTROLS



ACTUATOR FEEDBACK



### INDUSTRIAL



ROTARY ENCODERS



MOTOR POSITION SENSING



SERVO FEEDBACK



VALVE CONTROL SYSTEMS



The Tocos Angle Sensor IC provides precise angle measurement with a linear analog output and customizable parameters, making it ideal for a wide range of automotive, off-highway, and industrial position sensing applications.

# TOCOS ANGLE SENSOR IC

This is a magnetic angle sensor IC that integrates dual MR sensor bridges, signal processing, diagnostics, NVM and interface in a single chip.

## FUNCTIONAL BLOCK DIAGRAM

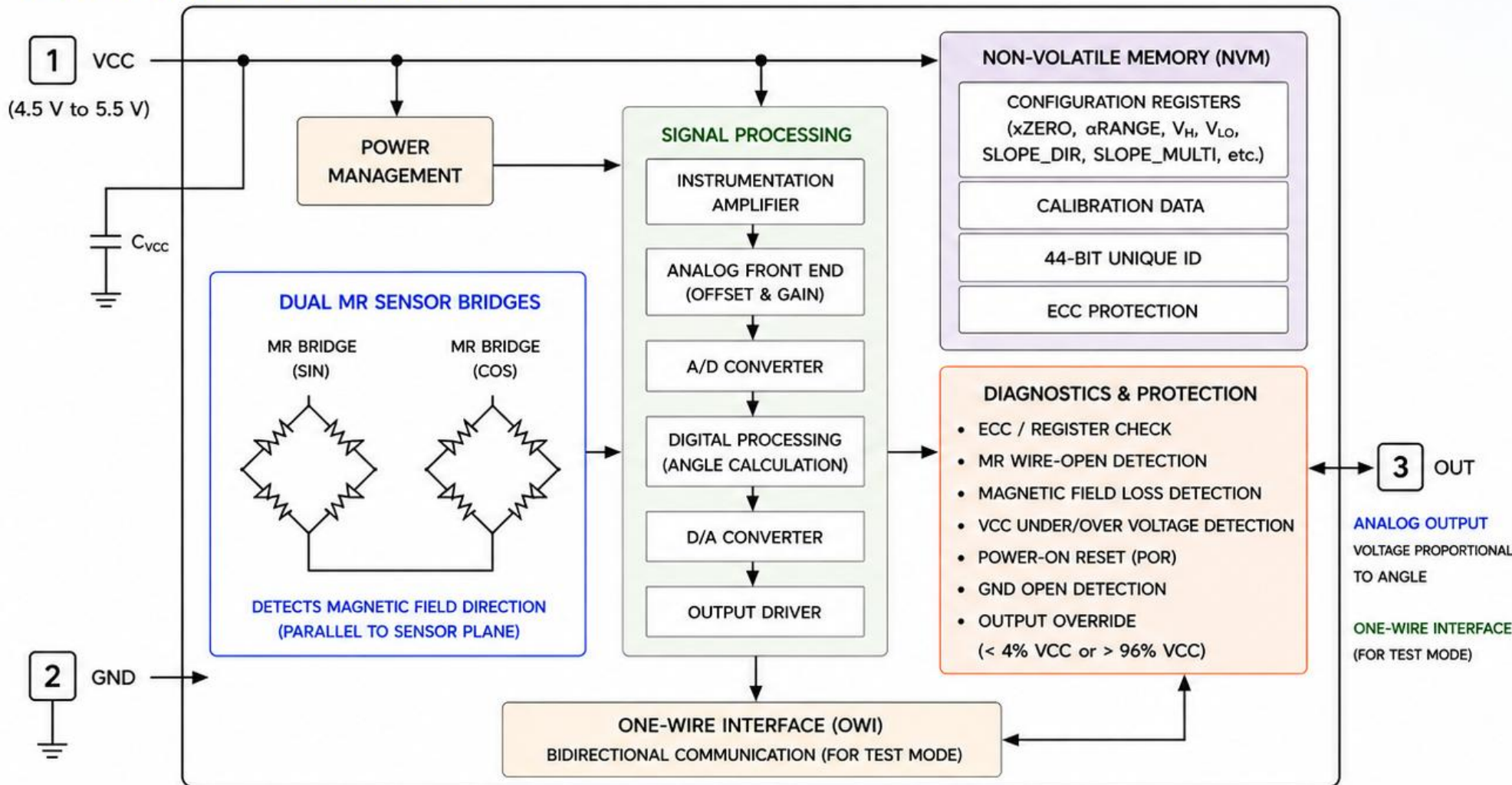

**1. DUAL MR SENSOR BRIDGES**  
Two orthogonal MR bridges (SIN & COS) detect the external magnetic field components.

**2. SIGNAL PROCESSING**  
Amplifies, digitizes and processes the sensor signals to calculate angle. The result is converted to an analog voltage proportional to angle.

**3. NON-VOLATILE MEMORY (NVM)**  
Stores all configurable parameters, calibration data and unique ID. ECC ensures memory integrity.

**4. DIAGNOSTICS & PROTECTION**  
Continuously monitors device and environment to detect faults and forces the output to a safe level when a fault occurs.

**5. ONE-WIRE INTERFACE (OWI)**  
Used to read/write registers, program parameters, read ID and perform diagnostics during test mode.

**NOTE:**  
During normal operation, the OUT pin outputs analog voltage proportional to the detected angle. When entering test mode, the same pin is used for One-Wire bidirectional communication.

→ SIGNAL FLOW  
— POWER / REFERENCE

# Principle of Angle Detection Using an AMR Sensor

The AMR angle sensor utilizes the magnetoresistive effect, in which the resistance of a magnetic material changes depending on the relationship between its magnetization direction and the surrounding magnetic field. The magnetic field generated by a magnet placed parallel to the AMR sensor IC is detected using two Wheatstone bridge-configured AMR sensor pairs, arranged with a 45-degree phase offset. Variations in resistance produce two output voltages corresponding to sin and cos waveforms, enabling detection of the magnet rotation angle  $\alpha$ . Since an AMR sensor cannot distinguish between the N and S poles of a magnet, the detectable angle range is 180 degrees.

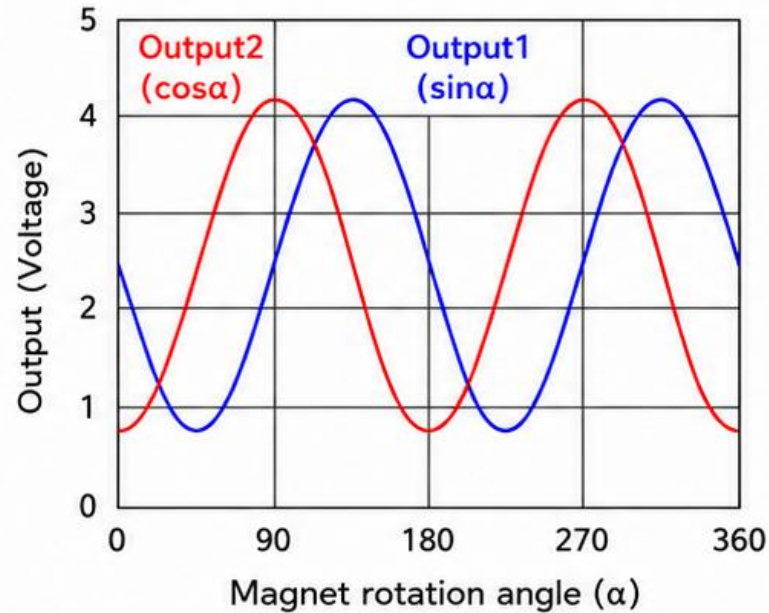
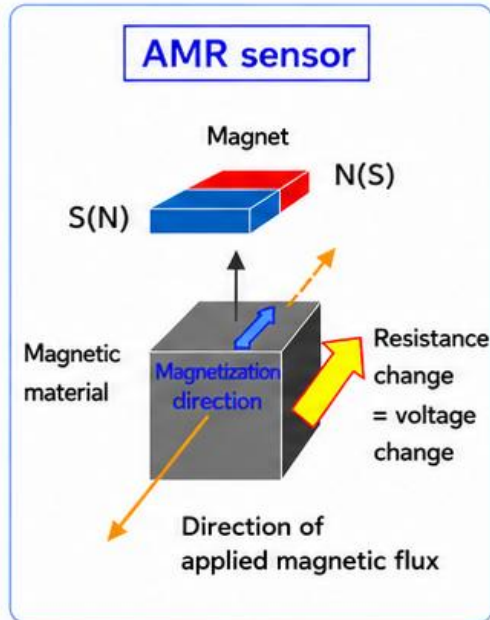
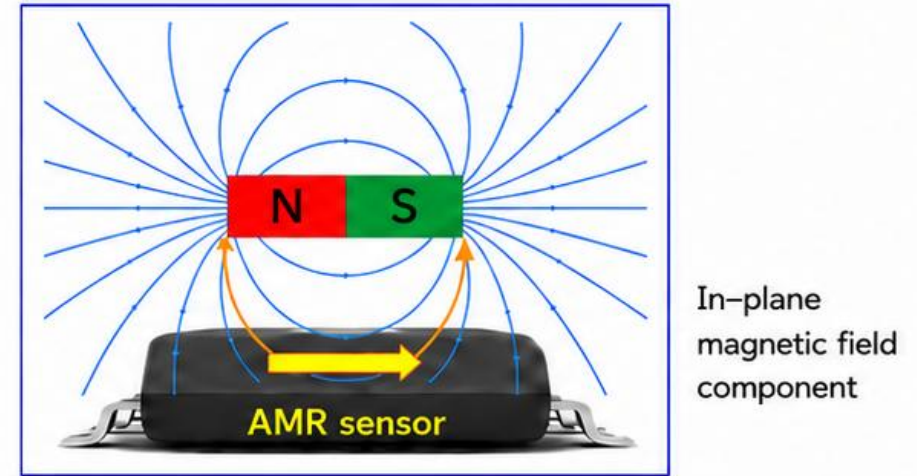

Two sets of AMR sensors configured in Wheatstone bridge structures (arranged with a 45-degree offset)

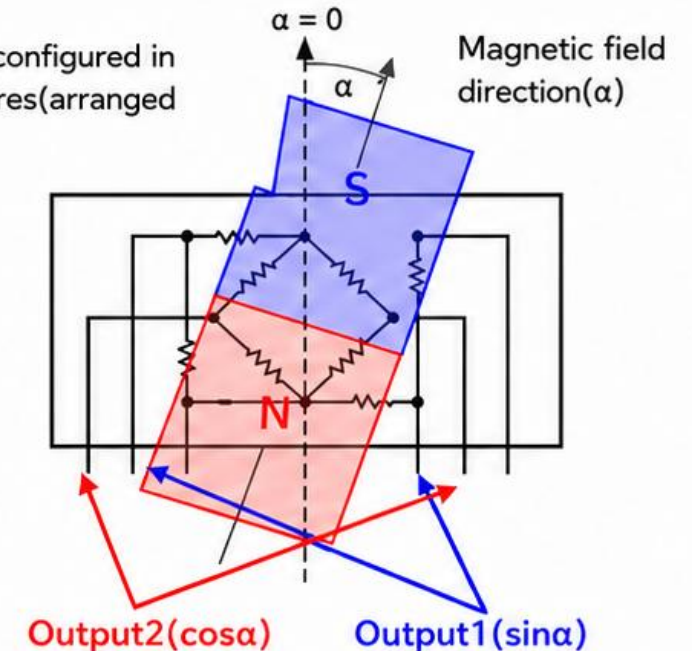

# Principle of Angle Detection Using a Hall Sensor

The Hall angle sensor uses the Hall effect, in which a voltage is generated in a direction perpendicular to both the current flow and the magnetic field. A magnetic field perpendicular to the angle sensor IC is generated by a facing magnet. The voltages output from four Hall sensors integrated on the IC are combined to generate two output signals corresponding to  $\sin\theta$  and  $\cos\theta$ , allowing detection of the magnet rotation angle  $\theta$ .

$$\text{Signal1} = +V_{HS1} + V_{HS2} - V_{HS3} - V_{HS4} \leftarrow \sin\theta$$

$$\text{Signal2} = +V_{HS1} - V_{HS2} - V_{HS3} + V_{HS4} \leftarrow \cos\theta$$

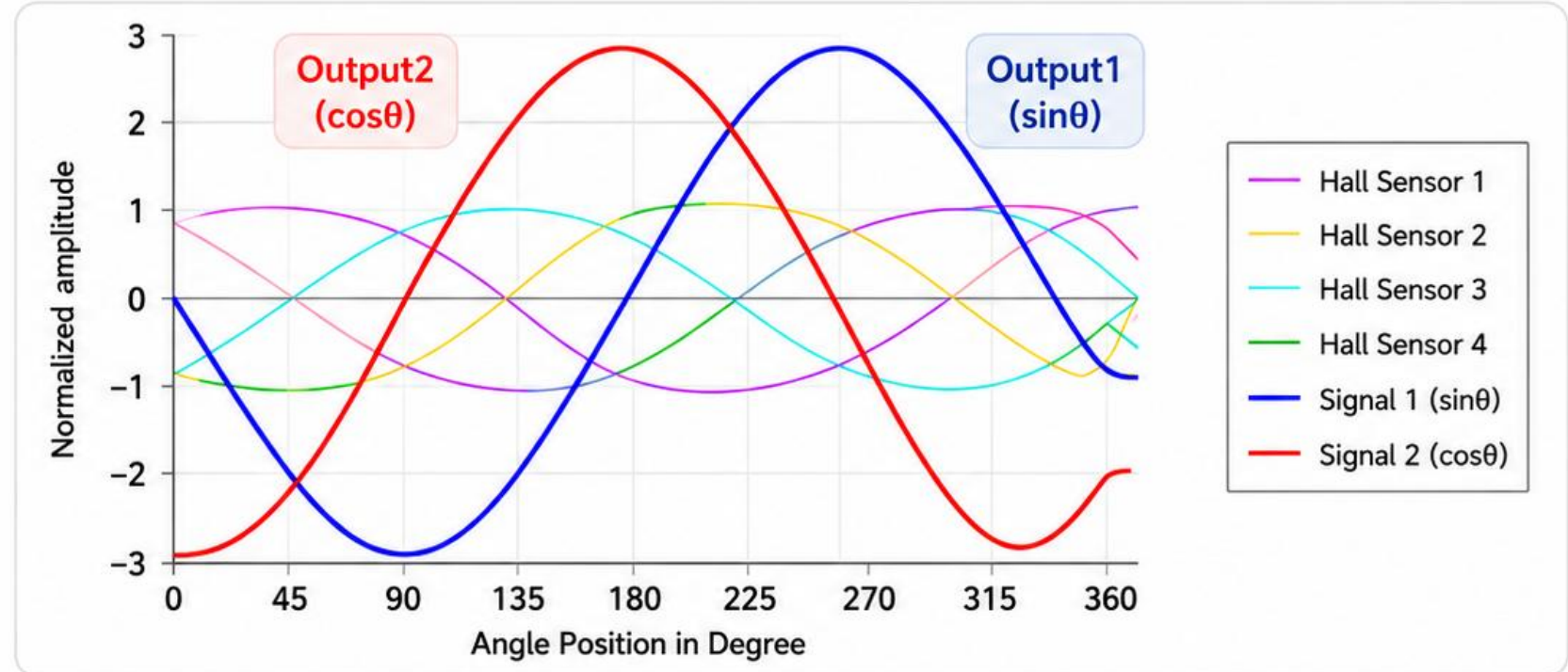
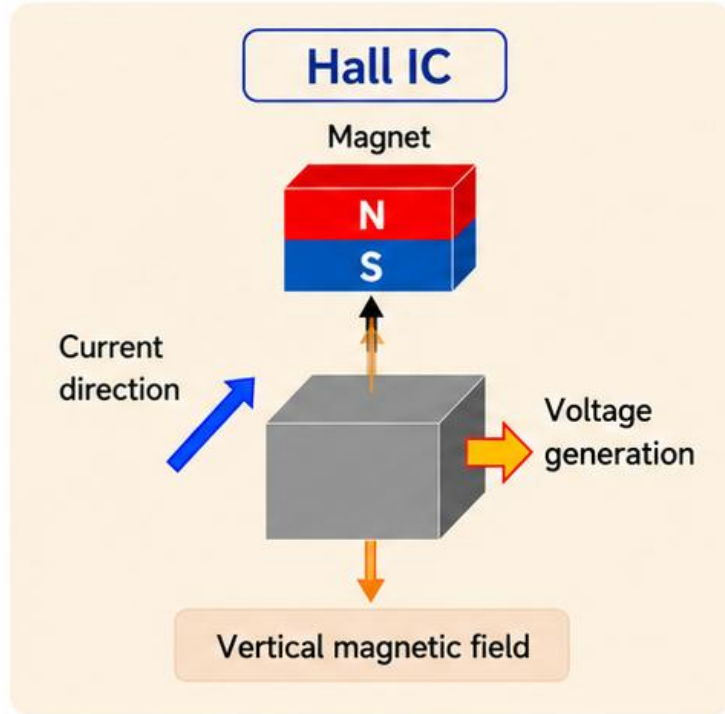

# Comparison of Angle Detection Principles: Hall Sensor vs. AMR Sensor

## Hall sensor

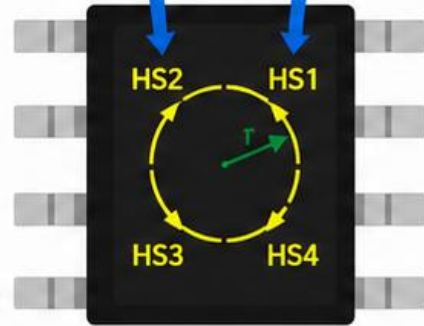
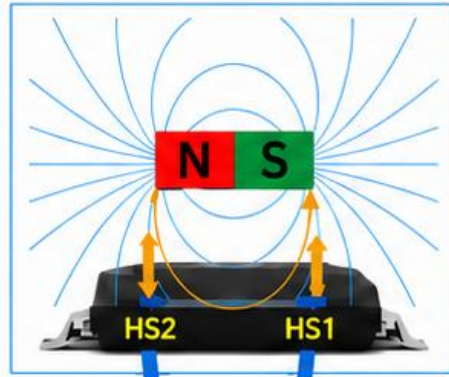

Four Hall sensors arranged concentrically (HS1/2/3/4)

Angle calculation from four sensors

$$\text{Signal1} = +V_{HS1} + V_{HS2} - V_{HS3} - V_{HS4} \propto \sin\theta$$

$$\text{Signal2} = +V_{HS1} - V_{HS2} - V_{HS3} + V_{HS4} \propto \cos\theta$$

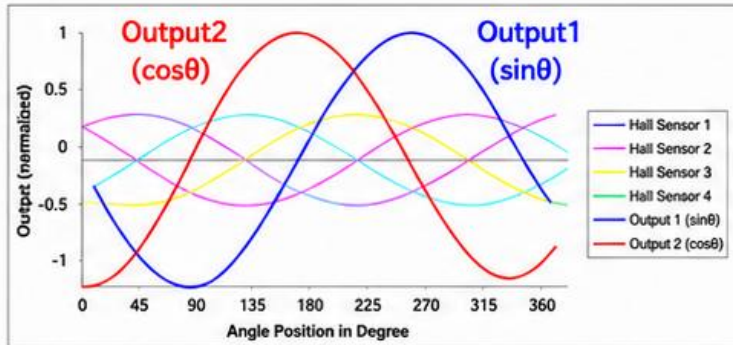

IC supplier:  
Melexis,  
Infineon(OSRAM)

## AMR sensor

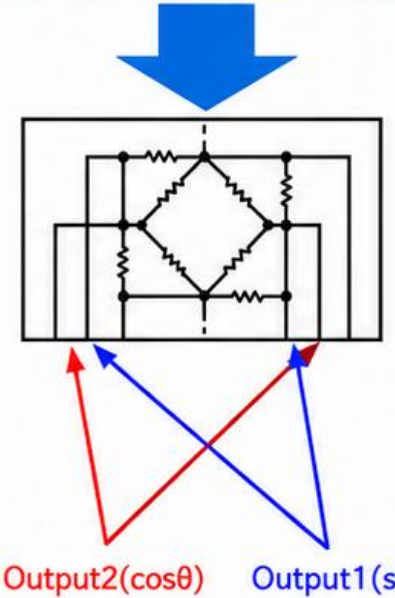
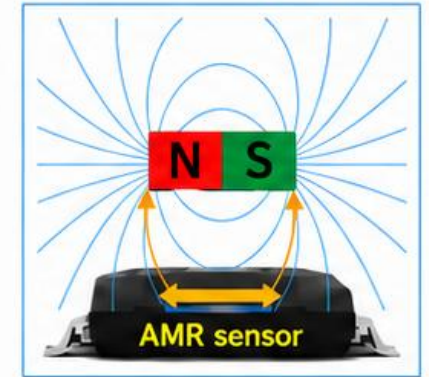

The AMR sensor measures the output of bridge structures composed of four combined sensor elements.

The Hall sensor calculates the angle by processing the outputs of four independent sensors.



Measure outputs from two sets of AMR sensors  
※Wheatstone bridge structures arranged with a 45-degree offset

IC supplier:  
TOCOS (Tokai Rika)

# Definition of Sensor Accuracy (INL, temp. drift, etc.) (analog output)

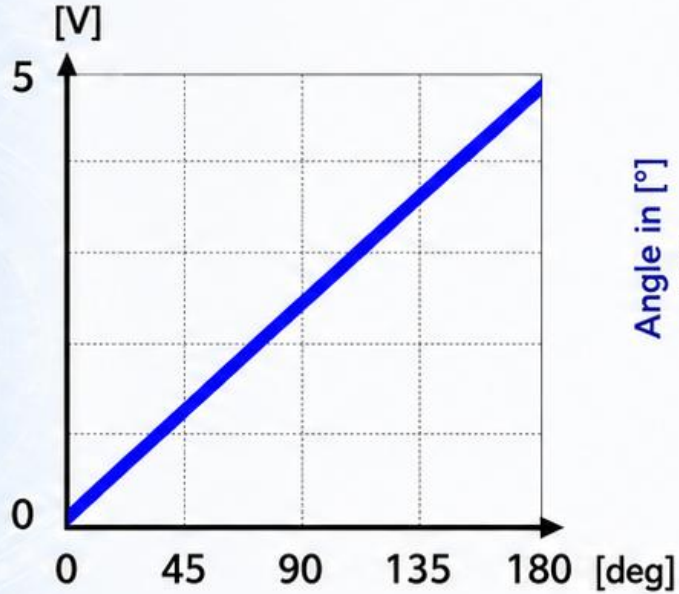

Angle input – Analog output

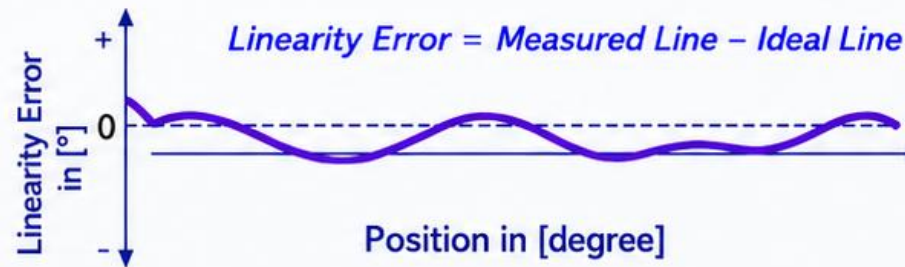
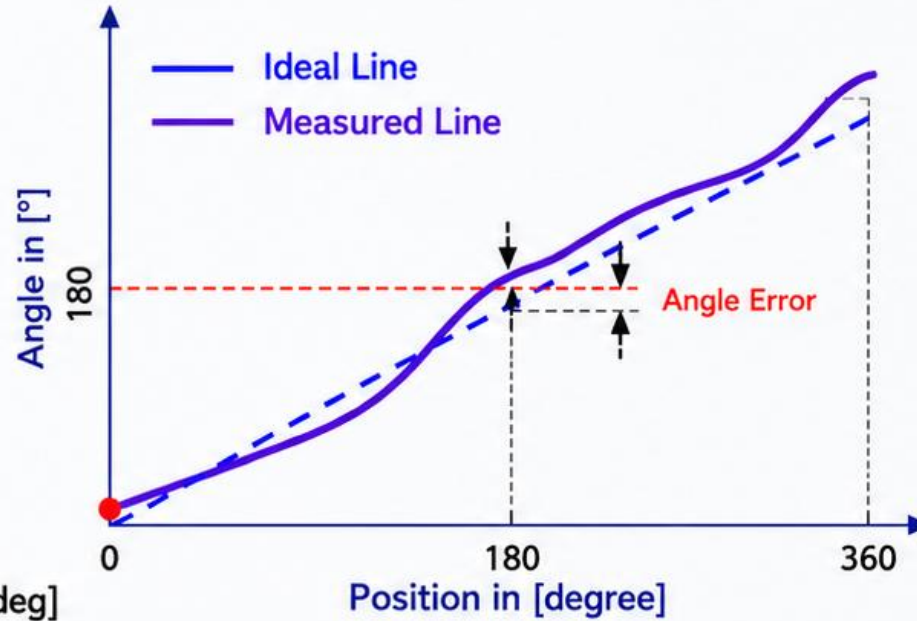

Non-linearity of the angle output

$$\text{INL Error} = \frac{\text{Linearity Error max} - \text{Linearity Error min}}{2}$$

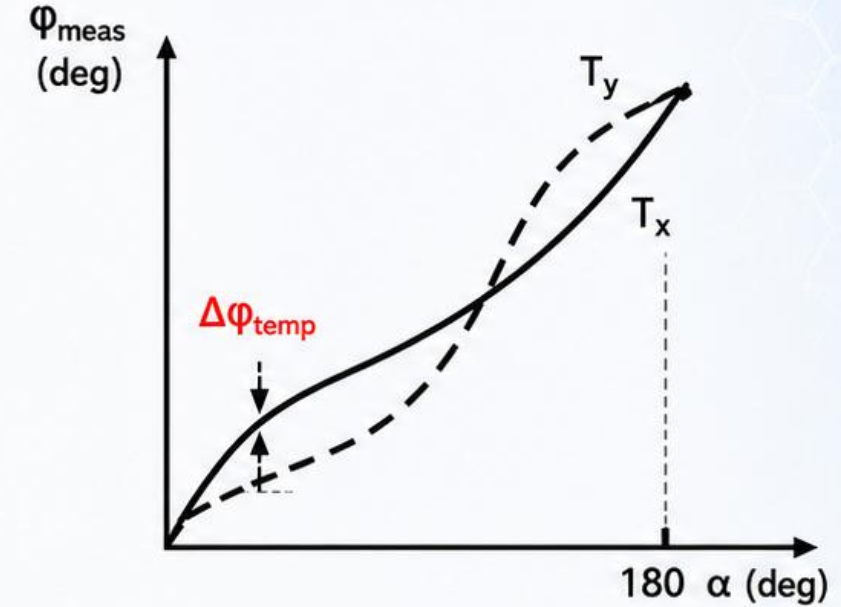

Definition of the temperature drift error

- $T_x$  : Output at low temperature
- $T_y$  : Output at high temperature
- $\Delta\phi_{\text{temp}}$  : Difference in angle due to temperature change

# Angle Sensor IC Development Schedule

## Start of sales activities

Marketing / Sales

